



54, 55, 56, 57, 58, 59

61 or 63
FT WHL X 10

60 or 62
FT WHL X 1

36-PID, 37-PID, 38-PID, 39-PID, 40-PID, 41-PID

FRONT VIEW

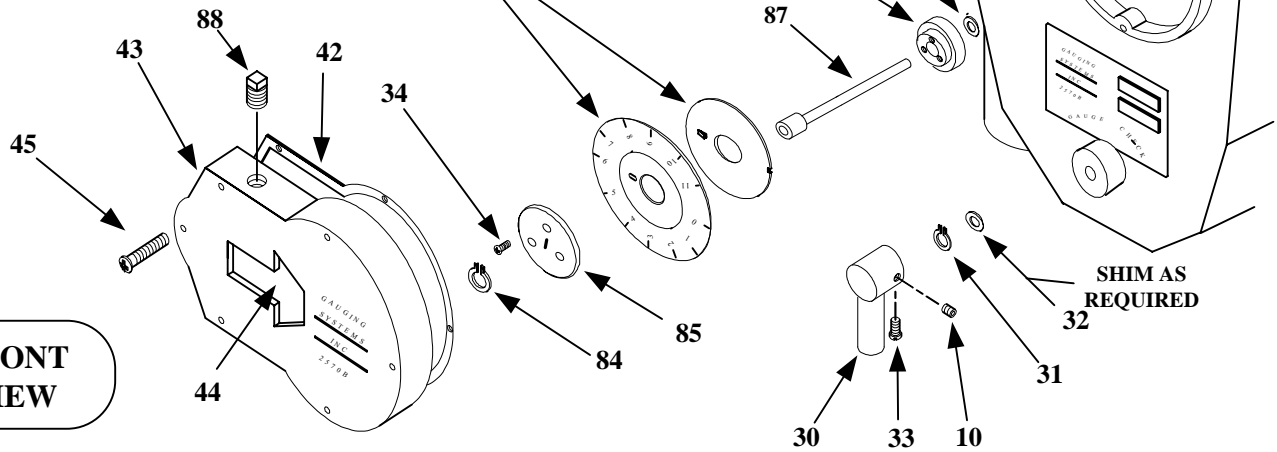

REAR VIEW

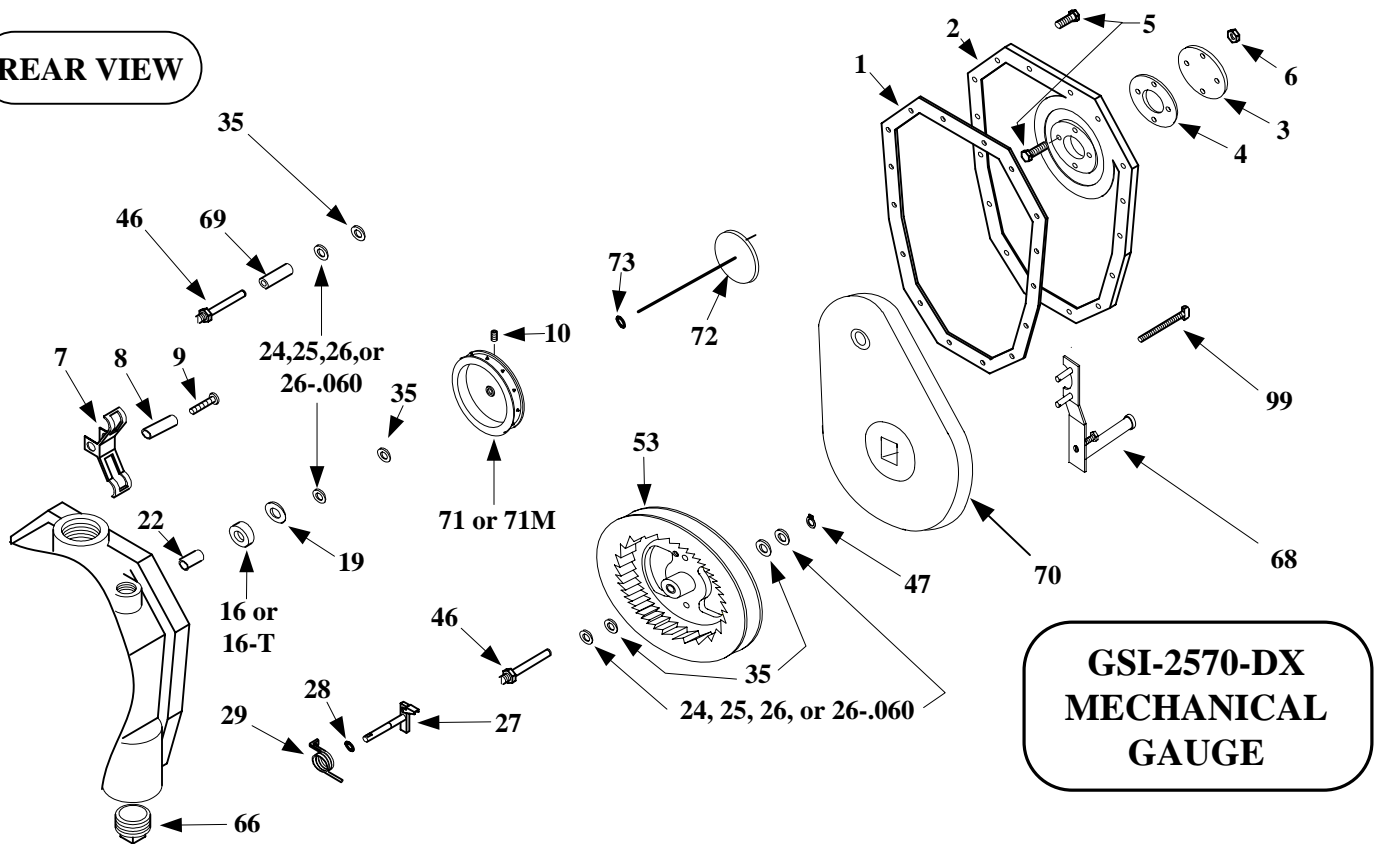

**GSI-2570-DX
MECHANICAL
GAUGE**

SEE BACK OF THIS PAGE FOR LIST OF PARTS NUMBERS AND DESCRIPTIONS:

EXAMPLE: Item Number 7 on Drawing will be G-2570-7 in the Parts List

Determine part/s needed from drawings above and fill in the quantities on the reverse side. Provide your name, e-mail, company, address, phone, fax, e-mail, and forward the list for quotation to:

Gauging Systems Inc. (GSI)

910 Industrial Blvd. · Suite A · Sugar Land · Texas · 77478
 Phone: (281) 980-3999 · Fax: (281) 980-6929 · E-mail: gshoutx@msn.com
[Http://www.gaugingsystemsinc.com](http://www.gaugingsystemsinc.com)

Gauging Systems Inc. (GSI), P.O. Box 680, Sugar Land, TX. 77487-0680 • Phone 1-800-444-1327 • Fax 281-980-6929

Name: _____	E-mail: _____	
Company: _____	Phone: _____	Fax: _____
Bill To: _____ _____ _____	Ship To: _____ _____ _____	

QTY	PART NO.	CROSS REF.	DESCRIPTION	PRICE	AMOUNT
	G-2570-1		Back Cover Gasket		
	G-2570-4	B5059-071	Cap Gasket *		
	G-2570-7	BA11346	Tape Keeper, Includes Items 8 & 9 *		
	G-2570-10		Set Screw, 1/4-20 x 3/8 *		
	G-2570-14	P25-16	Pinion Gear *		
	G-2570-16		Seal, Rubber		
	G-2570-16T	B10221-093	Seal, Teflon *		
	G-2570-19		Gland Washer		
	G-2570-24		Shim, .005 Thick, S/S *		
	G-2570-25		Shim, .010 Thick, S/S *		
	G-2570-26		Shim, .040 Thick, S/S *		
	G-2570-27	BA14055	Checker Assembly, Includes Item 28, 32 & 31 * (1)		
	G-2570-28		“O”-Ring, Buna *		
	G-2570-29	B7796-005	Checker Spring *		
	G-2570-30	B7792-011	Checker Handle, Includes Item 10 & 33 *		
	G-2570-31		Snap Ring		
	G-2570-32		Shim		
	G-2570-34		Screw, 8-32 x 3/8 *		
	G-2570-35		Shim, Teflon *		
	G-2570-36-PID		Inch Dial, Fractional Innage, Includes Dial Gear *		
	G-2570-37-PID		Inch Dial, Fractional Outage, Includes Dial Gear *		
	G-2570-38-PID		Inch Dial, Decimal Innage, Includes Dial Gear *		
	G-2570-39-PID		Inch Dial, Decimal Outage, Includes Dial Gear *		
	G-2570-40-PID		Dial, Metric Innage, Includes Dial Gear *		
	G-2570-41-PID		Dial, Metric Outage, Includes Dial Gear *		
	G-2570-42		Counter Cover Gasket		
	G-2570-43		Counter Cover		
	G-2570-44		Counter Cover Glass		
	G-2570-45		Screw, 1/4-20 x 1-1/2 *		
	G-2570-46	BA7763	Sheave Assembly Shaft, 1/2-20 Threads *		
	G-2570-47	P10-2	Sheave Assembly Snap Ring *		
	G-2570-53		Tape Storage Sheave Assembly For NC2500B *		
	G-2570-54	BM18849-100	Counter Assembly, English Innage *		
	G-2570-55	BM19954-100	Counter Assembly, English Outage *		
	G-2570-56		Counter Assembly, Decimal Innage *		
	G-2570-57		Counter Assembly, Decimal Outage *		
	G-2570-58	BM18850-100	Counter Assembly, Metric Innage *		
	G-2570-60	D6045-000	Foot Wheel X 1, Innage *		
	G-2570-61	D6046-000	Foot Wheel X 10, Innage *		
	G-2570-62	D6342-000	Foot Wheel X 1, Outage *		
	G-2570-63	D6343-000	Foot Wheel X 10, Outage *		
	G-2570-70		Negator Cassette (1)		
	G-2570-71		Sprocket, English: use with the GSI-DCA		
	G-2570-71M		Sprocket, Metric: use with the GSI-DCA		
	G-2570-73		“O”-Ring		
	G-2570-84		Snap Ring		
	B7795-005	B7795-005	Replacement Hair Spring, Checker Assembly *		

Items 85, 86, 87, 72 are Sold Only in the DCA Assembly, Part Number GSI-DCA.

FOOT NOTES:

- * Improved parts are interchangeable within other manufacturers gauges
- (1) Available in kit form, consult GSI
- For a complete list of part numbers, See the GSI 2570 DX Gauge Kit Manual